



MASON INDUSTRIES, Inc.

MERCER RUBBER Co.

350 Rabro Drive, Hauppauge, NY 11788
Mason- 631/348-0282 • Info@Mason-Ind.com
Mercer- 631/582-1524 • Info@Mercer-Rubber.com
FAX 631/348-0279



JOB NAME
CUSTOMER
CUSTOMER P.O.
MASON M.
DWG No.

CSAFFL

SS BRAIDED HOSE
with CARBON STEEL
FIXED & FLOATING
FLANGES

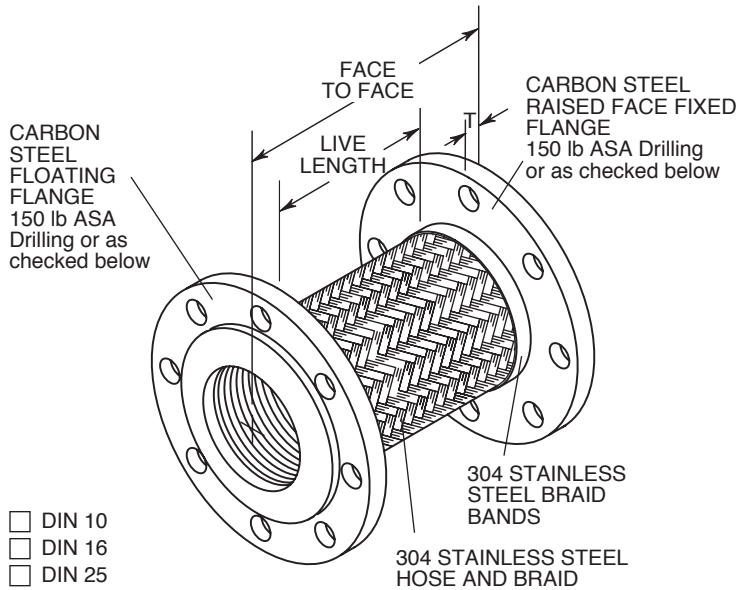

- DIN 10
DIN 16
DIN 25
ASA-300

OPTIONAL FITTINGS MATERIAL
as checked below

Stainless Steel



These assemblies have been
"CSA International" approved
for use on gas pipelines. "CSA
International" is the current
certification agency for gas
industry products, assuming the
authority formerly associated with
the American Gas Association (AGA).

Our Certification Report is #230720-1764990.
This Certification meets all requirements of
ANSI/UL #536 2003 Standards for Flexible
Metal Hose.

PLATE FLANGE THICKNESS

Table with 3 columns: Pipe Size (in/mm), Flange Thickness T (in/mm), and values for 1 1/2 thru 4 inch pipe sizes.

CSAFFL DIMENSIONS AND PRESSURE RATINGS (American Units)

Table with 7 columns: Pipe Size & Face to Face (in), Live Length (in), Maximum Permanent Lateral Offset (in), Corrugations per foot, Rated Pressure @70°F (psi), Min Burst Pressure (psi), Safety Factor.

CSAFFL DIMENSIONS AND PRESSURE RATINGS (Metric Units)

Table with 7 columns: Pipe Size & Face to Face (mm), Live Length (mm), Maximum Permanent Lateral Offset (mm), Corrugations per meter, Rated Pressure @21°C (kg/cm²), Min Burst Pressure (kg/cm²), Safety Factor.

Face to Face Tolerance: minus 1% plus 3%. Lateral Offset one side of centerline and normal machinery vibration.
If intermittent in both directions, reduce by 50%.

Inventory table with columns: QTY, SIZE, TAG

Inventory table with columns: QTY, SIZE, TAG