

US-WV

Ultrasonic energy meters

Ultrasonic energy meters for horizontal or vertical mounting.

US-WV is a range of externally threaded, compact energy meters intended for heating or cooling.

Function

The menu system, available in the display, makes it possible to read a large number of parameters, such as heat and cold consumption, total energy spent on heating and cooling, temperatures along with current energy consumption.

Installation is normally in the return pipe.

US-WV comes equipped with two PT500 temperature sensors. The resistors for the sensors are composed of platinum and maintain a standard of DIN IEC 60751.

Mounting

The US-WV model flow meters are designed for horizontal or vertical mounting positions.

The calculator can be wall mounted or DIN rail mounted.

One temperature sensor is mounted inside the flow meter and the other has a 3 m cable.

Nominal flow sizes

US-WV is available in nominal flows between q_p 1.5 m³/h ...10 m³/h. See selection table on page 2.

High reliability

The calculator features a high accuracy of measurement, in addition to a long life and robust design. The calculator utilizes EEPROM memory, meaning loss of data does not occur if the battery is changed.

Short facts about US-WV

- Compact meter with easy-to-read display
- No data loss when changing battery
- Constant display of energy consumption
- For horizontal or vertical mounting
- Available with M-Bus, pulse output or M-Bus and 2 pulse inputs

Flexible design

Due to the multiple combination options offered by its components, meters in the US-WV range can easily be adapted to suit a large number of individual requirements. Models with M-Bus, pulse output or M-Bus + pulse input are available.

Energy meters with M-Bus have a default address of "0", which is not a valid primary communication address.

This primary address can be changed by searching for secondary addresses (i.e., the ID number of the meter).

For more information on different options, see ordering examples and item number structure overleaf.

Ordering code selection table

Options	US-WV				
	1.5 m ³ /h (DN15) (G3/4") (110 mm)	15-1,5			
	1.5 m ³ /h (DN20) (G1") (190 mm)	20-1,5			
	2.5 m ³ /h (DN20) (G1") (190 mm)	20-2,5			
	3.5 m ³ /h (DN25) (G1 1/4") (260 mm)	25-3,5			
	6.0 m ³ /h (DN25) (G1 1/4") (260 mm)	25-6,0			
	10 m ³ /h (DN40) (G2") (300 mm)	40-10			
Type of measurement and installation point	Heating, installation of flow meter in return pipe (MID approval)		-	HR	
	Cooling ¹ , installation of flow meter in return pipe		-	CR	
	Heating and cooling in combination ² , installation of flow meter in return pipe		-	HCR	
Communication interface	M-Bus with power supply			-	M
	M-Bus with 2 pulse inputs			-	MPI
	Pulse output for energy			-	PO

¹ National German approval.

² MID approval for heating, not for cooling.

If any further requirements or options are needed, please contact Regin.

Ordering code table explanation**Example 1:**

Desired application: Meter with 1.5 m³/h. Heating, installation in return pipe. M-Bus.

Resulting item ordering number: **US-WV15-1,5-HR-M**

Possible accessories needed:

- KH-¼, 2pcs, ball valve connection for both sides of the meter, alternatively brass fittings VSR-½
- KH-S-¼, 1pc, ball valve with temperature sensor pocket for forward flow

Example 2:

Desired application: Meter with 2.5 m³/h. Cooling, installation in return pipe. M-Bus + pulse input.

Resulting item ordering number: **US-WV20-2,5-CR-MPI**

Possible accessories needed:

- KH-1, 2pcs, ball valve connection for both sides of the meter, alternatively brass fittings VSR-¾
- KH-S-1, 1pc, ball valve with temperature sensor pocket for supply flow

Accessories

Brass threaded fittings with coupling ring and gasket

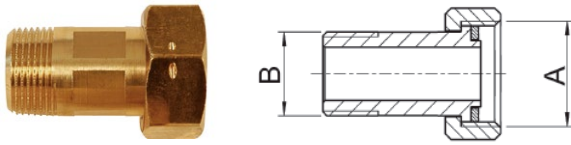

Meter DN	Connection A	Connection B	Compatible with	Article number
15	G $\frac{3}{4}$	R $\frac{1}{2}$	q _p 0.6/1.5 m ³ /h	VSR- $\frac{1}{2}$
20	G1	R $\frac{3}{4}$	q _p 0.6/1.5/2.5 m ³ /h	VSR- $\frac{3}{4}$
25	G1 $\frac{1}{4}$	R1	q _p 3.5/6 m ³ /h	VSR-1
40	G2	R1 $\frac{1}{2}$	q _p 10 m ³ /h	VSR-1 $\frac{1}{2}$

Ball valves with coupling ring and gasket

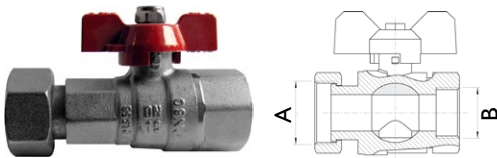

Meter DN	Connection A	Connection B	Compatible with	Article number
15	G $\frac{3}{4}$	R _p $\frac{3}{4}$	q _p 0.6/1.5 m ³ /h	KH- $\frac{3}{4}$
20	G1	R _p 1	q _p 0.6/1.5/2.5 m ³ /h	KH-1
25	G1 $\frac{1}{4}$	R _p 1 $\frac{1}{4}$	q _p 3.5/6 m ³ /h	KH-1 $\frac{1}{4}$
40	G2	R _p 2	q _p 10 m ³ /h	KH-2

Ball valves with installation point for a temperature sensor (sockets M10x1)

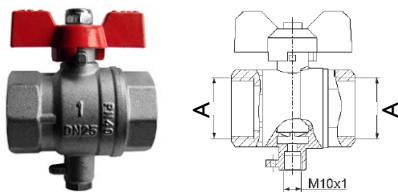

Meter DN	Connection A	Compatible with	Article number
15	G $\frac{3}{4}$	q _p 0.6/1.5 m ³ /h	KH-S- $\frac{3}{4}$
20	G1	q _p 0.6/1.5/2.5 m ³ /h	KH-S-1
25	G1 $\frac{1}{4}$	q _p 3.5/6.0 m ³ /h	KH-S-1 $\frac{1}{4}$
40	G2	q _p 10 m ³ /h	KH-S-2

Accessories, cont.

Forward flow adapter with gasket, for direct mounting of temperature sensor in T-piece



Connection A	Article number
G $\frac{1}{2}$, M10x1	VAD- $\frac{1}{2}$ "
G $\frac{3}{8}$, M10x1	VAD- $\frac{3}{8}$ "

Threaded adapters to replace flow meter temporarily or permanently



Meter DN	Connection A	Installation length L	Compatible with	Article number
15	G $\frac{3}{4}$	110 mm	q _p 0.6/1.5 m ³ /h	PS-110- $\frac{3}{4}$
20	G1	190 mm	q _p 0.6/1.5/2.5 m ³ /h	PS-190-1
25	G1 $\frac{1}{4}$	260 mm	q _p 3.5/6 m ³ /h	PS-260-1 $\frac{1}{4}$
40	G2	300 mm	q _p 10 m ³ /h	PS-300-2

Installation example, heating

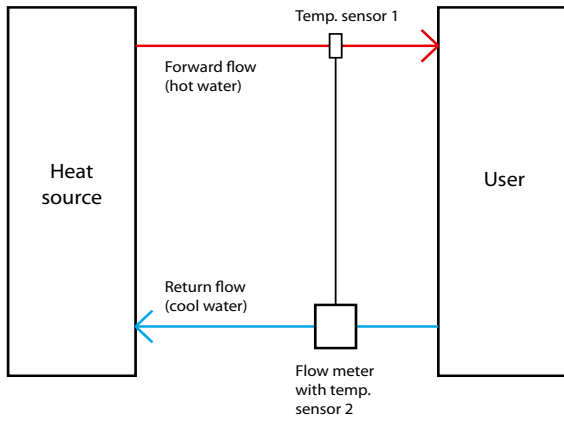

Installation example, cooling

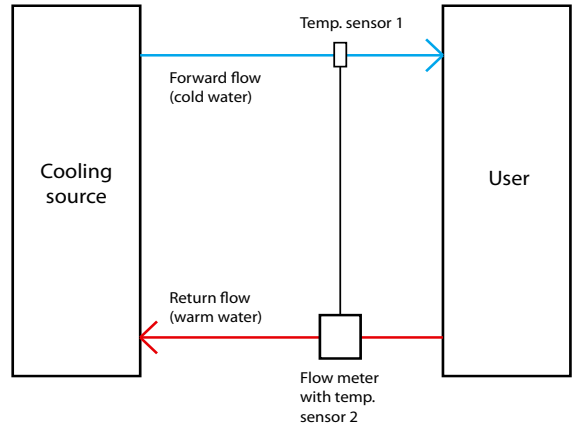

Pressure drop curve

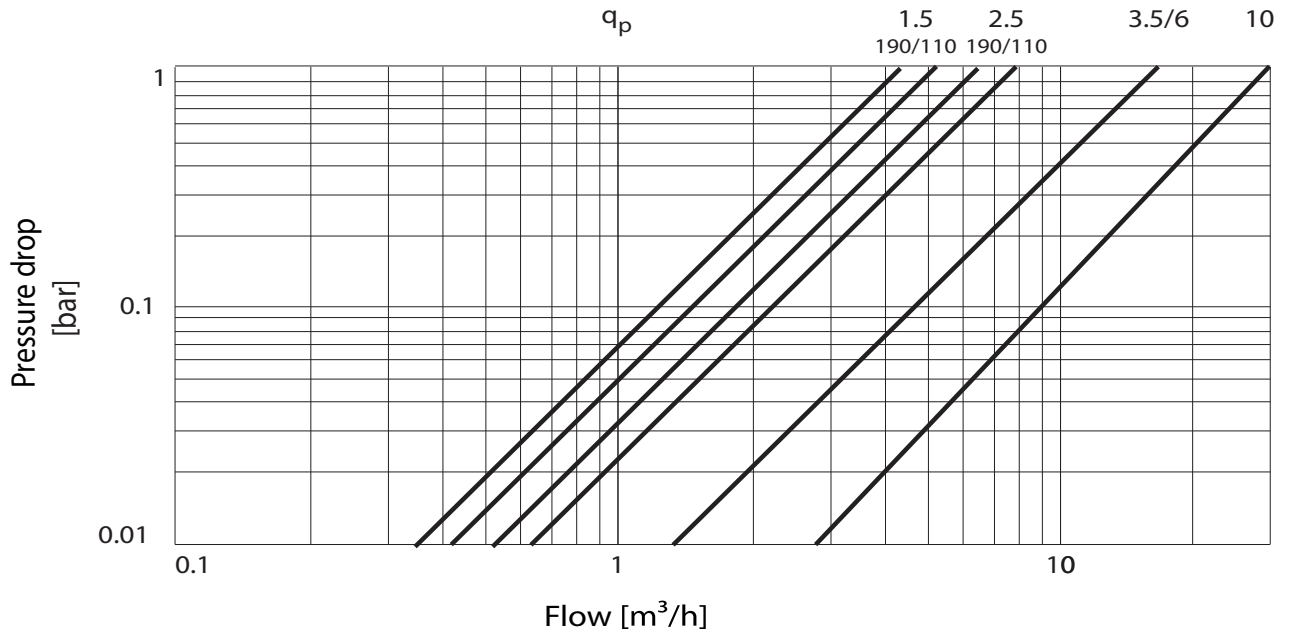

Technical data, calculator

Temperature measurement range calculator	1 ... 150 °C
Temperature difference range heat	3 ... 100 K
Temperature difference range cooling	-3 ... -50 K
Ambient temperature	5 ... 55 °C
Calculation of heat from K	$\Delta\Theta > 0.05$
Calculation of cooling from K	$\Delta\Theta < -0.05$
Resolution temperature	0.01 °C
Measuring frequency	Cycle 30 s
Display	LCD, 8 digits + additional symbols
Display units	MWh, kWh, GJ, m ³ , m ³ /h, l/h, kW, MW, °C
Interfaces	M-Bus, pulse output or M-Bus with 2 pulse inputs
Power supply	Battery 3.6 V lithium
Data storage	EEPROM, daily storage of values
Billing dates	Annual billing date selectable, 24 monthly values
Storage of maximum values for flow and power	3 values each
Protection class housing	
Heating	IP54
Cooling	IP65
Mechanical class	Class M1 (MID: 31.03.2004 annex I)
EMC	Class E1 (MID: 31.03.2004 annex I)
Flow meter installation position	Standard: return flow
Dimensions (L x W x H)	198 x 123.7 x 45.8 mm
Weight of calculator	250 g (approx.)



Measuring Instruments Directive: This product conforms to the requirements of the Measuring Instruments Directive 2004/22/EC through product standards OIML R75, EN 1434, EN 60751, EN 14154 and PTB-Richtlinie K 7.1.

Low Voltage Directive (LVD) standards: This product conforms to the requirements of the European Low Voltage Directive (LVD) 2006/95/EC through product standards EN 61140, VDE 0140-1, EN 60529 and DIN 40050.

EMC emissions & immunity standards: This product conforms to the requirements of the EMC Directive 2004/108/EC through product standards EN 13757-2, EN 13757-3 and DIN 12900-1.

RoHS: This product conforms to the Directive 2011/65/EU of the European Parliament and of the Council.

Technical data, flow meter

Nominal flow q_p (m ³ /h)	1.5	2.5	3.5	6	10
Nominal diameter DN (mm)	15	20	25		40
Pressure rating (PN)	16				
Maximum flow q_s (m ³ /h)	3	5	7	12	20
Minimum flow q_i (l/h)	0.015	0.025	0.035	0.06	0.1
Flow at 0.1 bar pressure drop (m ³ /h)	1.3/1	1.7/2	4.4		8.9

Media	Water (only permissible media)
Maximum temperature range	5... 130°C *
Temperature range heating	10... 130°C **
Temperature range cooling	5... 50°C
Mounting position by cooling	Transducers (black housing) to side of or under the measuring tube

* National approvals may differ.

** For short versions: 20...130°C.

Technical data, cont.

Technical data, temperature sensors

Platinum precision resistors
Sensor diameter
Sensor cable length
Installation

PT500; separately approved type as per EN60751, unshielded
Ø 5.0 mm
3 m
Direct or indirect in a temperature pocket per EN1434

Application

Heat meter
Cooling meter

Temperature sensor requirements

EU (MID) identification on the temperature sensors
National German approval as a temperature sensor
for cooling meters *

* Requirements in countries other than Germany may be different.

Dimensions, US-WV

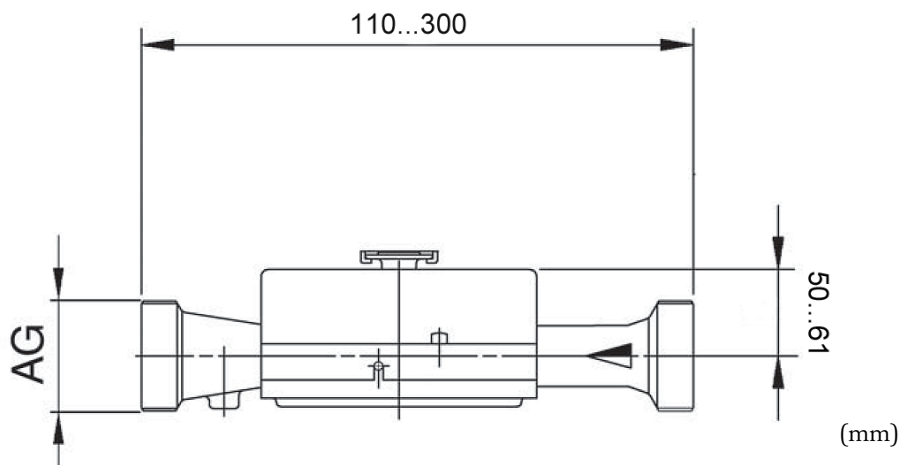

Dimensions, calculator

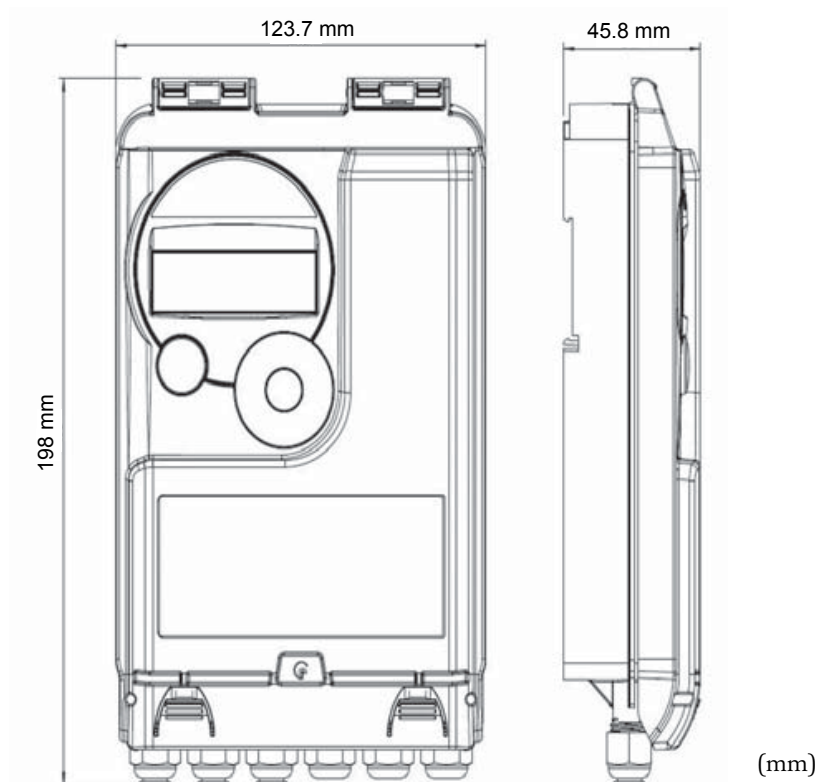

Head Office Sweden

Phone: +46 31 720 02 00

Web: www.regincontrols.com

Mail: info@regin.se